

Pulper for Cherries



Model DP-24



Model DP-12

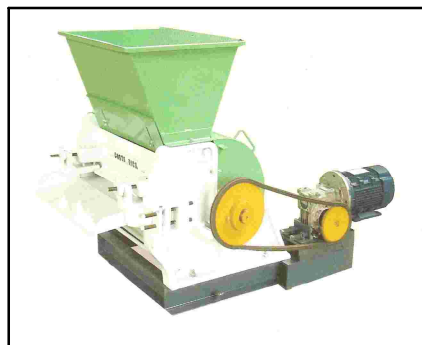

Model DP-04

Function:

Its function is to remove the coffee pulp in fruit and separate the pulp of the grain by means of the friction between the shirt and the bibs.

Two types:

- Coffee pulp remover with rubber bibs which is recommended to process first quality coffee.
- Coffee pulp remover with iron bibs which is used to process inferior qualities coffee.





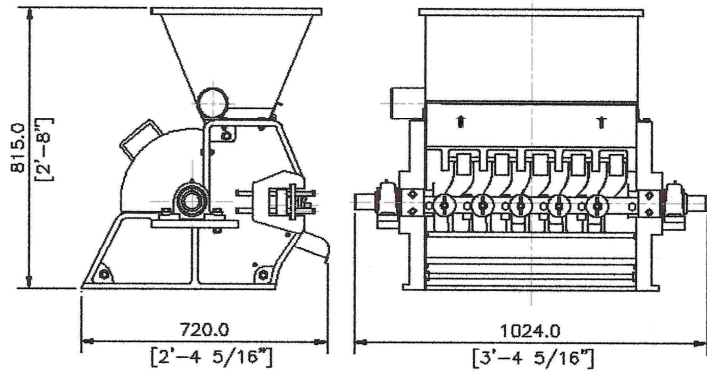
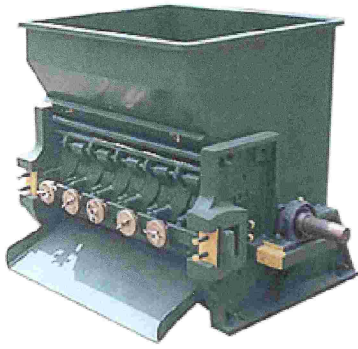

Equipment description:

They have an horizontal cylinder of 15 inches of diameter by 24 inches length in cast iron or in aluminium for use of stainless steel or copper case, the axis of 1 3/4" diameter mounted on bearings of rolls driven by means of pulleys or pinions the performance per hour of the machine is 30 quintals parchment coffee per hour.



Technical Specs:

- The driving force of the Pulper is between 1 and 2.5 HP
- Bib rubber speed = 150 R.P.M.
- Bib iron speed = 175 R.P.M.

Technical Specifications of Pulpers			
MODEL	WORKING CONDITIONS	CAPACITY Kgr / hr	MOTOR HP
DP-8M 	easy	275	Manual
DP-8E 	easy	600	1.0
DP-12 	heavy	2000	1.5
DP-24 	heavy	4000	2.5
DI-12 	heavy	1750	1.5
DI-24 	heavy	3500	2.5

Cimbria Heid GmbH
 Heid Werkstrasse 4
 A-2000 Stockerau, Austria
 Telefon: (43) -2266-6990
 Telefax: (43) -2266-65590
 E-mail : heid@cimbria.at - wbo@cimbria.at
 Internet: www.cimbria.com

