

# Gravity Separator GA 70



Grains or particles of almost identical size are fed continuously on the separating deck surface of the separator, providing a uniform bed of material over the deck surface.

The deck is fluidised by a completely uniform pressurised air system stratifying the light material to the top of the product bed and allowing the heavy material to contact the deck surface. The deck is inclined from side to side and inlet end to discharge end at adjustable angles.

The deck itself is powered by a fully balanced eccentric drive which moves the deck at low amplitude and high frequency up hill. The heavy material contacting a specially designed square wire deck surface moves up hill, while the light material fluidised by the air system moves down hill due to gravitational pull. A typical separation pattern is depicted below.

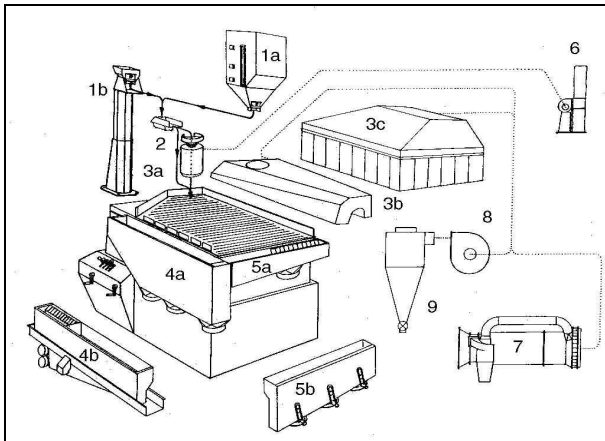

- 1a. Intake pre-storage hopper**  
for intake adjustment between feeder-elevator and electro-magnetic feeder SP 18 incl. 3 level indicator switches.  
Delivery with or without supporting legs
- 1b. Feed hopper with supporting column**  
to be arranged before the electro-magnetic feeder in case of direct feeding of product.
- 2. Electro-magnetic feeder type SP 18**  
for the troublefree, continuous feeding of the machines.
- 3a. Intake dust-aspiration hopper**  
light dust and fines removal from the product to be cleaned. Connection to central dust exhaust unit.  
Air requirement: 10 m<sup>3</sup>/min, 300 Pa.
- 3b. Partial dust hood**  
In case of heavy dust formation, for the removal of dust from the incoming material and the light produce area.

Connection to central dust exhaust or individual cyclone and ventilator. Incl. Intake dust-aspiration hopper and frame.

- 3c. Full dust hood**  
complete closed; suction over the whole table area. With frame.
- 4a. Discharge hopper for heavy product**
- 4b. Vibrating discharge trough for heavy product with stone trap.**
- 5a. Vibrating discharge trough for light product**
- 5b. Bagging-off type hopper**  
for design with BASE STRUCTURE (required, if BAGGING-OFF type hoppers instead of discharge hopper will be supplied.
- 6. Combined fan and cyclone filter unit**
- 7. Cyclofan**
- 8. Exhaust fan**  
With motor, without support structure
- 9. Dust separating cyclone with rotary valve**

Capacity:	t / h	lbs / h
corn, wheat, soybeans	4	8800
peas, beans	3	6600
clover	1.6	3500
rape seed	1.2	2600
Fan drive:	kW	hp
	4	5.5
Reciprocating drive	kW	hp
	0.55	0.75
Table area	m <sup>2</sup>	ft <sup>2</sup>
	1.5	16
Air requirements:	m <sup>3</sup> /min	CFM
	250	8800
Dimensions:	cm	inch
Length	203	80
Width	130	51
Height	117	46
Weights:	kg	lbs
Net	678	1490
Land transport	830	1830
Sea transport	940	2073
Volume	m <sup>3</sup>	ft <sup>3</sup>
Sea packed	7	250

Technical data can vary for certain of the above due to continued development, or a different machine composition.

Copyright Ó - The right to alterations is reserved

