

Cimbria Cleaner



What We Call "Grain Care" Means "A Great Many Advantages" For You

Quality

The quality of all the material and components in Cimbria Delta cleaners is uncompromisingly high. More than a thousand machines and plants world-wide are operating everyday and are proof of the quality we represent.

Experience - An Extra Security

We offer you professional advice which ensures the best solution to meet your specific needs.

Accuracy And Careful Cleaning

Are key words in our development and production of cleaners. Owing to a careful method of processing the quantity of seed undamaged, and capable of germinating is increased and thus an increase in the value of the saleable material is achieved. Your earnings are increased and you are ensured a quicker return on your investment.



Flexibility

Delta cleaners are constructed of standard modules which can be built together and ensure that your specific need for a particular cleaning process will always be met. Quick and simple change of sieves results in more crops per machine in less time and less investment in sieves, as the sieves fit in 80% of all cleaners (exclusive of Mega cleaners)

Complete Range Of Products And Total Solutions

The highest flexibility possible and optimal design of the best plant possible are guaranteed by the possibility of buying all machines from one supplier. Cimbria's ownership of Cimbria Heid in Austria means that we have a complete range of machines at our disposal which can solve even the most complicated cleaning process. All delivered from one company.

Research, Tests And Training

Research, tests and training take place at Cimbria's full-scale seed-grain plant. We are willing to carry out test cleaning of a given crop when extra safety is requested, and we can also determine the exact sieve perforations for special processes.

A World-wide Network Of Distributors

Cimbria has a wide network of experienced distributors who are continuously informed of the latest technical knowledge of cleaning process, new product adaptations and re-developments. They all have a service organisation at their disposal, which ensures you the best and quickest service.

Considerations To The Environment

Considerations to the environment are an extremely important factor for Cimbria. That is in terms of the production as well as the environment in which the plant is to operate. Therefore we offer efficient dust separation, noise attenuation, saving of energy and recirculation of the air. Cimbria is continuously trying to be abreast of developments in the environmental area so that we always meet the requirements in force no matter where in the world we deliver.



World-Wide Experience

Cimbria have great experience in cleaning- and processing of numerous products world-wide. A Cimbria cleaner is a safe investment for you, as you have the possibility to clean different grains in the plant.



Beans

Fennel



Maize

Sorghum



Coffee

Rough meadowgrass



Rape seed

- Wheat
- Rye
- Oat
- Barley
- Malt
- Rape seed
- Rybs
- Mustard seed
- Grass seed
- Spinach's
- Caraway
- Sugar beet
- Peas
- Soya beans
- Maize
- Sunflower
- Rice
- White rice
- Coffee
- Cocoa beans
- Peanuts

We offer advise and design of plants for all sorts of cleaning purposes and various products based on research achievements and many years practical experience.



The Cimbria Delta 120-Series

Developed for the sizing of grain and seed

- consists of 7 models with a sieve area of 1 - 24 m²
- can manage 2 - 6 fractions in a single flow
- grades accurately because of long travel via Z-flow



Full-width Vibratory

- has stepless adjustment of the feed rate by a separate control panel
- ensures a uniform flow over the entire width of the sieve
- is self-cleaning
- improves the air cleaning considerably as the product hits the pre-suction area uniformly
- is careful to leguminous seeds, beet seeds etc.
- ensures optimal capacity utilisation of the machine
- has no down time due to choked up inlet
- requires no cleaning in connection with changing products

Feed Roller With Built-in Stirrer

- has feedgate which in combination with variable RPM control of the feed rate
- ensures by means of the stirrer that no product build-up is created in the inlet by light products such as grass seeds etc.
- is insensitive to light waste material and large impurities such as stones etc.
- has a built-in spring loaded safety device which secures the feed roller against damage



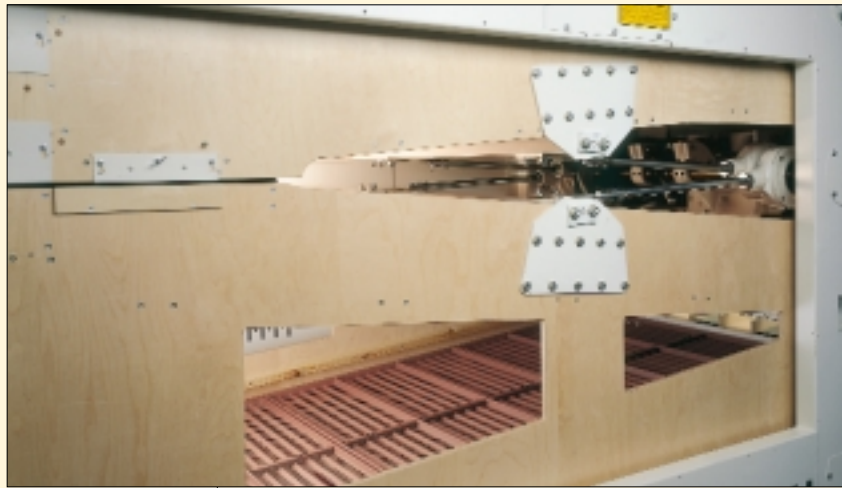

Screenshoes Of Birch Plywood

- are moisture- and insect-resistant
- are constructed with replaceable wear plates and sieve runners in exposed areas
- have a long lifetime because the birch plywood easily tolerates the vibrations of the screen shoes
- give less resonance owing to the birch plywood and thus a better working environment is obtained

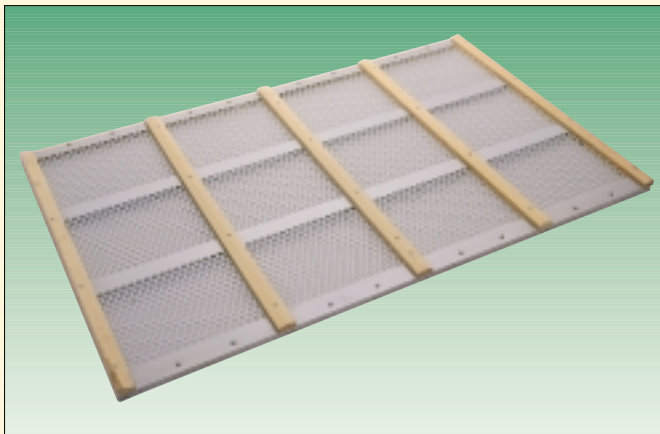

Cimbria Delta Sieves For All Purposes

- are available with round and long holes from 0,3 to 25,0 mm
- are also available as wiremesh screens
- are also available as screen plates with very little tolerance which ensures a minimum cleaning loss.
- are available in a standard size of 800 mm (L) x 1250 mm (B) = 1 m², which can be used in more than 80% of the Cimbria Delta programme so the number of sieves needed is reduced

Ball Box

- ensures efficient cleaning of sieves by means of rubber balls
- can maintain the cleaning effect at extremely low temperatures as the rubber balls are cast in a very suitable material
- is cast solid so that it prevents stuck seeds etc. (self-cleaning)
- is separately mounted in the screen shoes which ensures a quick change of sieves without removing the ball boxes

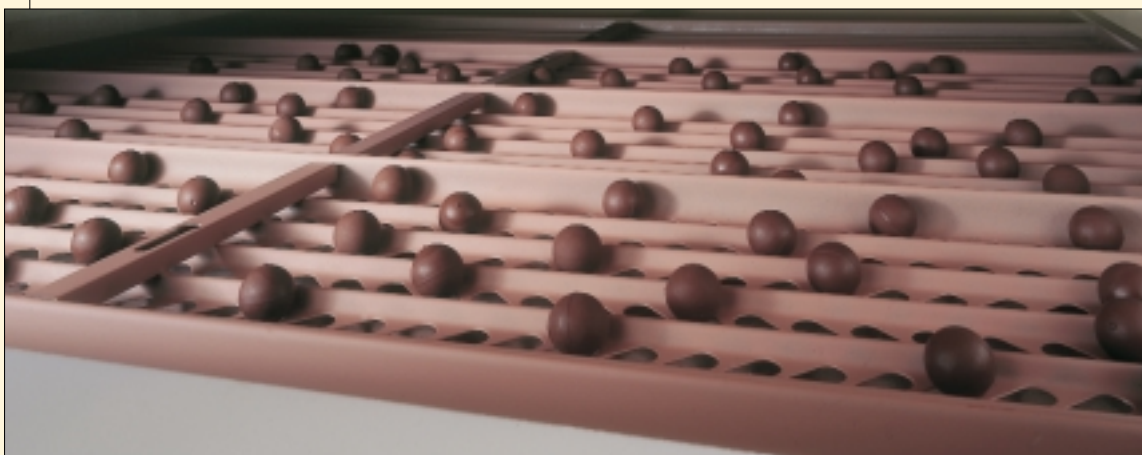

The Cimbria Delta 110-Series

Compared to the 120-series but extended with an efficient pre- and after suction system, a minimum for high-quality cleaning of leguminous seed, malting barley, seed grains etc.

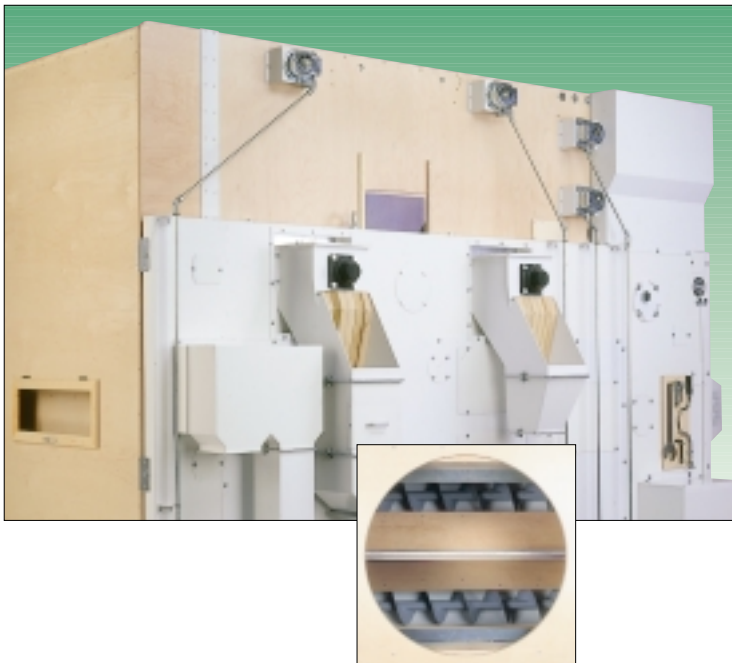

Pre- And After Suction System

- is built as separate systems to ensure a precise and independent air cleaning
- separates the light particles before the material reaches the sieves
- improves the cleaning effect and results in a higher capacity
- ensures an excellent purity of the product due to the suction of light particles such as empty seeds, husks, dust etc. when the product leaves the cleaner via the air screen

Alternative Pre- And After Suction System

- built as two separate recirculation air units
- reduces the need for external air to 20% compared to traditional systems
- can be connected to existing central aspiration systems due to the small air volume
- reduces costs of construction and operating costs of aspiration
- reduces the energy consumption



Screw Conveyor For Light Waste

- ensures continuous discharge of dust and light waste from the air system via screws
- with finger flaps to ensure optimal dust separation in the expansion chamber by preventing false air from entering into the chamber



Balanced Eccentric System

- is fitted with counter weights ensuring steady running
- involving minimum stress on buildings and steel structures
- is fitted with "heavy duty" bearings
- ensures maximum utilisation of the cleaning effect of the sieves owing to accurately attuned stroke and RPM



Change Of Product Flow

- makes many different product flows possible according to the capacity, product, number of fractions etc.
- by means of six different diagrams in the cleaner
- ensures excellent purity and minimum waste
- is easily done by changing the size of the sieves and the position of the outlet trays





The Cimbria Delta 100-Series

Is compared to the 120- and 110-series extended with a highly efficient air lifting system developed by Cimbria.

Cimbria Delta Super cleaners ensure excellent efficiency and purity in the cleaning of all kinds of crops such as garden seeds, grass seeds, flower seeds, corn, leguminous seeds etc.

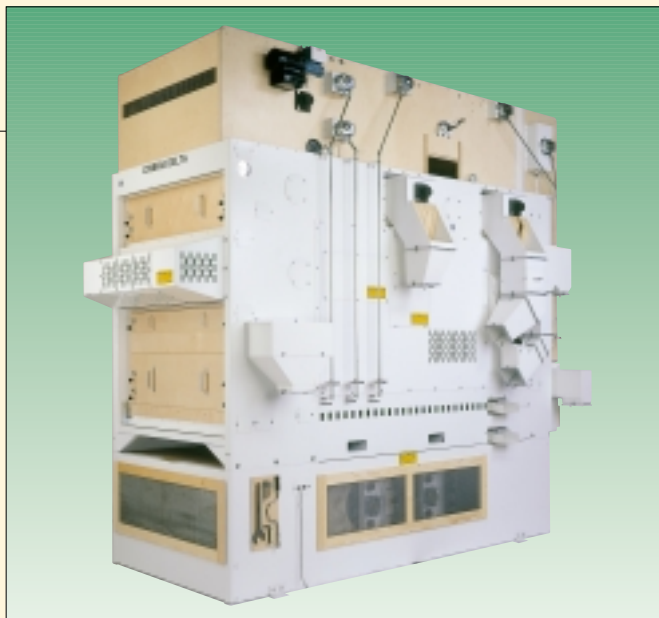

Air Lifting Unit



- is capable - by means of staggered fans and air guides - of giving a completely uniform air pressure from beneath the product when it leaves the cleaner
- ensures a complete blow-through of the product which causes an elimination of light seeds, husks, straw and dust
- with specially designed impellers ensuring low noise level
- has stepless adjustment of RPM on the fans

Air Lifting Channel

- eliminates light seeds in the variable expansion chamber
- through which husks, dust etc. are led with the airflow to the after suction system
- is available with an extra large expansion chamber and centre outlet for special processes



Air Lifting Sieve Screen

- serves to convey the product through the air flow to ensure elimination of light particles
- forces the product under passage to turn its biggest surface against the air flow in order to obtain optimal separation
- is constructed with adjustable air lifting hood over the air lifting sieve, which ensures optimal collecting up of the discarded light particles
- is combined with air lifting hood, designed with inspection window in full width, in order to make the adjustment of the air volume easier



Finished Product Of A High Quality

- is clearly illustrated by the difference between the cleaned seed/product and the discarded light product over the air lifting system.
- reduces in many cases the size of the subsequent processing machines

Easy To Operate

- because all adjustments are placed at a suitable height
- owing to adjustments with scales for quick and precise re-adjustment
- since all operating handles are placed on the same side as the outlets
- is as standard with outlets and adjustments placed on the right hand side seen from the inlet end
- is available in special left-hand design



- 1 Inlet
- 2 Agitator
- 3 Spring-loaded feed valve
- 4 Pre-suction
- 5 Screens
- 6 Eccentric drive system for screen boats
- 7 After suction
- 8 Air lifting blowers
- 9 Outlet for second quality product
- 10 Expansion chamber

 Cimbria Delta Grader
120-series

 Cimbria Delta Fine
110-series

 Cimbria Delta Super
100-series

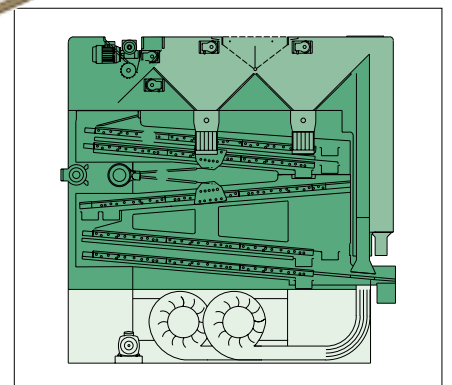
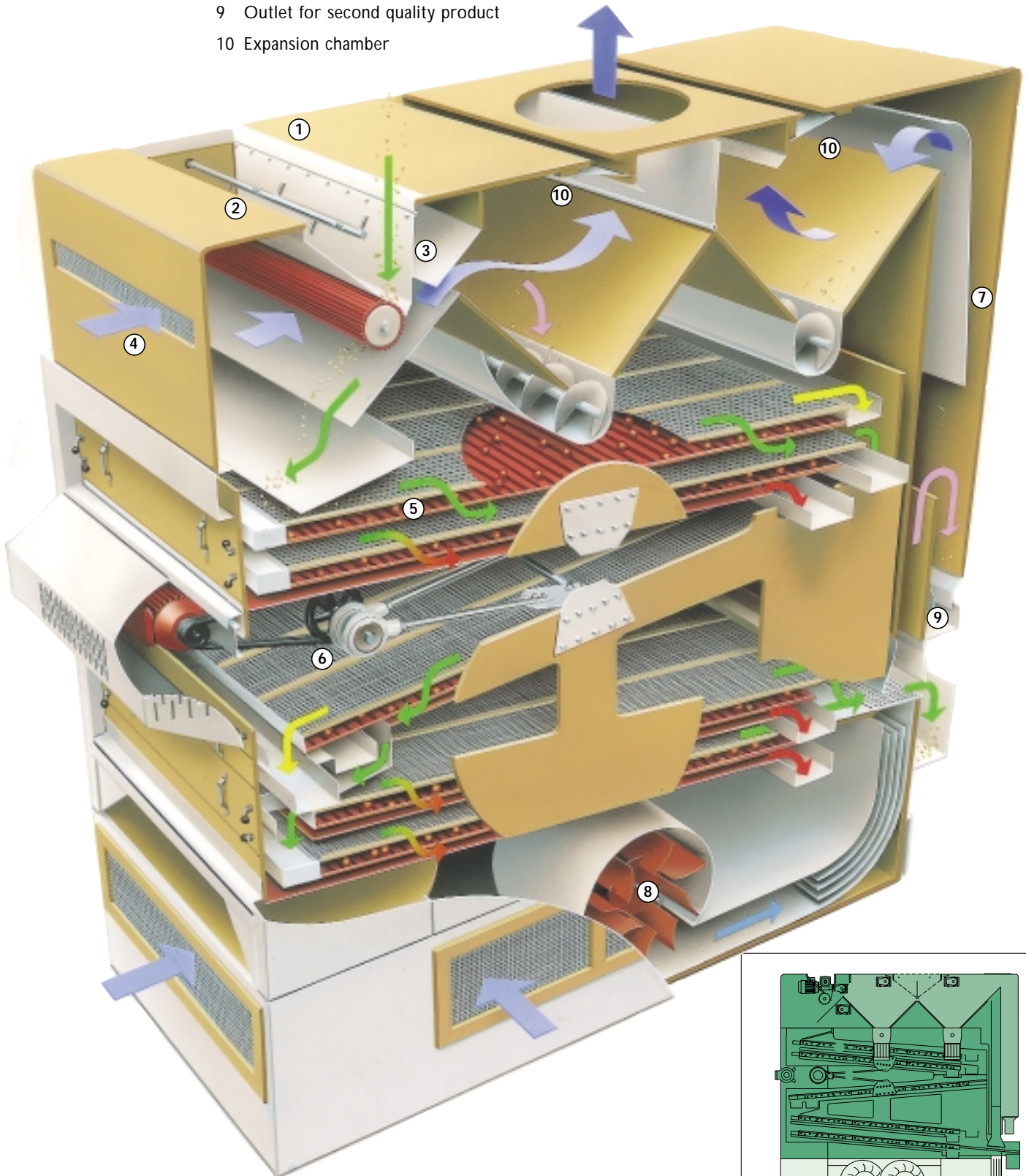



	Type	Screen area	Cereals						Legumes			Other products						
			Wheat, Rye, Sorghum	Barley	Oats	Maize	Raw rice	White rice	Soyabean	Pea	Clover	Ray grass	Rape seed	Sun flower	Suger beet	Raw coffee	Roasted coffee	
DELTA SUPER CLEANERS	101	0.96 m ²	0.2	0.2	0.1	0.1	0.08	0.1	0.08	0.08	0.04	0.04	0.04	0.04	0.04	0.08	0.04	
	102	3 m ²	2.5	2.5	2.0	2.0	1.5	2.0	2.0	2.0	0.5	0.4	2.0	1.0	1.2	2.0	1.2	
	104	7 m ²	5.0	5.0	4.0	4.0	3.0	4.0	4.0	4.0	1.0	0.75	4.0	2.0	2.5	4.0	2.5	
	105	10 m ²	7.5	7.5	6.0	6.0	4.5	6.0	6.0	6.0	1.6	1.6	6.0	3.0	3.5	6.0	3.5	
	106	15 m ²	12.0	12.0	9.0	9.0	7.0	9.0	9.0	9.0	2.2	1.8	9.0	4.5	5.0	9.0	5.0	
	107	18 m ²	20.0	20.0	16.0	16.0	12.0	16.0	16.0	16.0	3.5	3.0	16.0	8.0	9.0	16.0	9.0	
	108	24 m ²	25.0	25.0	20.0	20.0	15.0	20.0	20.0	20.0	5.0	4.0	20.0	10.0	11.0	20.0	11.0	
	111	0.96 m ²	0.2	0.2	0.1	0.1	0.08	0.1	0.08	0.08	0.04	0.04	0.04	0.04	0.04	0.08	0.04	
DELTA FINE CLEANERS	112	3 m ²	2.5	2.5	2.0	2.0	1.5	2.0	2.0	2.0	0.5	0.4	2.0	1.0	1.2	2.0	1.2	
	114	7 m ²	5.0	5.0	4.0	4.0	3.0	4.0	4.0	4.0	1.0	0.75	4.0	2.0	2.5	4.0	2.5	
	115	10 m ²	7.5	7.5	6.0	6.0	4.5	6.0	6.0	6.0	1.6	1.3	6.0	3.0	3.5	6.0	3.5	
	116	15 m ²	12.0	12.0	9.0	9.0	7.0	9.0	9.0	9.0	2.2	1.8	9.0	4.5	4.0	9.0	5.0	
	117	18 m ²	20.0	20.0	16.0	16.0	12.0	16.0	16.0	16.0	3.5	3.0	16.0	8.0	9.0	16.0	9.0	
	118	24 m ²	25.0	25.0	20.0	20.0	15.0	20.0	20.0	20.0	5.0	4.0	20.0	10.0	11.0	20.0	11.0	
	DELTA GRADERS	121	0.96 m ²	0.2	0.2	0.1	0.1	0.08	0.1	0.08	0.08	0.04	0.04	0.04	0.04	0.04	0.08	0.04
		124	7 m ²	5.0	5.0	4.0	4.0	3.0	4.0	4.0	4.0	1.0	0.75	4.0	2.0	2.5	4.0	2.5
125		10 m ²	7.5	7.5	6.0	6.0	4.5	6.0	6.0	6.0	1.6	1.6	6.0	3.0	3.5	6.0	3.5	
126		15 m ²	12.0	12.0	9.0	9.0	7.0	9.0	9.0	9.0	2.2	1.8	9.0	4.5	5.0	9.0	5.0	
127		18 m ²	20.0	20.0	16.0	16.0	12.0	16.0	16.0	16.0	3.5	3.0	16.0	8.0	9.0	16.0	9.0	
128		24 m ²	25.0	25.0	20.0	20.0	15.0	20.0	20.0	20.0	5.0	4.0	20.0	10.0	11.0	20.0	11.0	

All capacities are indicated in tons per hour



A/S Cimbria

Cimbria House - Boks 40
DK-7700 Thisted
Denmark
Phone (+45) 96 17 90 00
Fax (+45) 96 17 90 99
<http://www.cimbria.com>
E-mail: holding@cimbria.com

Cimbria Manufacturing A/S

Faartoftvej 22
DK-7700 Thisted
Denmark
Phone (+45) 96 17 90 00
Fax (+45) 96 17 90 99
E-mail: manufacturing@cimbria.com