

Data Sheet 37

Bucket Elevator EC5, EC6 & EC8



Cimbria Bucket Elevators are manufactured in different sizes with capacities ranging from 5 to 700 MT of wheat per hour (specific gravity 0.76 dry and cleaned) with EU-buckets and optimal

number of buckets per meter belt and nominal belt speed. Other products may require lower belt speed and other bucket distances for optimal operation.

m³/h	20	40	70	140	220	355	560	635	740	935
Type	EC5	EC6	EC8	ED10	ED12	EE14	EE18	EE20	EE24	EE32
	Data Sheet 37			See Data Sheet 38			See Data Sheet 39			

Cimbria bucket elevators type EC are supplied in easily assembled modular sections, in galvanised plate, alternatively a painted finish. The elevators are available with a wide range of accessories.

1. Elevator Top and Drive arrangement (Data sheet 37.1):

The elevator top is of bolted construction and as standard supplied with a right mounted hollow shaft gearbox with built in backstop. Alternatively with a directly mounted gearbox. Inside the top a plate guides the grain to the outlet. Outlet spout with horizontal connection to Q-flange. Top pulley has lamellas and is rounded to ensure max. friction and a straight running belt.

2. Elevator Bottom:

The elevator bottom is of bolted construction and as standard with a Cimbria low-speed guard (type PH for 220V/AC, 24V/DC or 24V/AC) which cuts off the power to the motor, if the belt starts to slip.

Built in hatch for manual cleaning of the bottom. The bottom is as standard fitted with a 45° inlet hopper and connection to Q-flange. The inlet is normally on the front side of the elevator (where the buckets move upwards in the leg). This position has the lowest power consumption. By light products is it an advantage to place the inlet on the back of the elevator (capacity is app. reduced with 20 %).

The belt tensioning is done from the elevator bottom by a hand wheel that adjust the bottom pulley downwards by two spindles.

3. Elevator Legging (Trunking):

The elevator legging is supplied in standard lengths of 1950 mm, to achieve the required elevator height loose flanges are supplied for the top set of legs. The legs can easily be connected via strong flanges. Distance pieces are supplied to bolt in between the leg sections. The front leg has an inspection door for easy access to belt and buckets.

Elevator Buckets / Belt (Data sheet 37.1):

The buckets are of a so called "high capacity" model, because the shape is good for high belt speeds and a close distance between the buckets. The belt is as standard of industrial quality, anti-static and black. Alternatively a fat and oil resistant belt can be supplied.

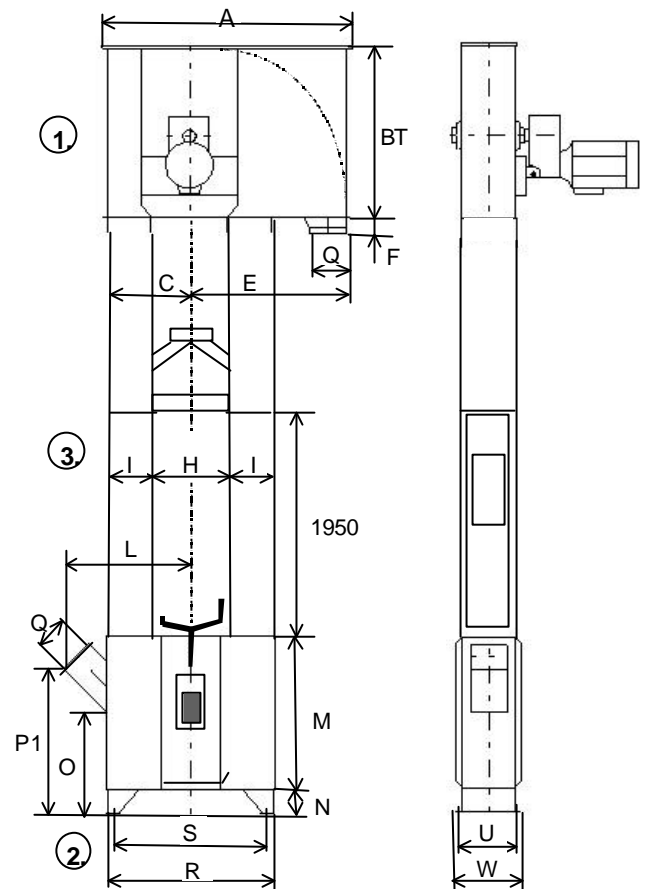

Extra Equipment:

- ✘ Misalignment switch for control of a straight running belt.
- ✘ Aspiration from both elevator legs.
- ✘ Plastic wearing plate in elevator top.
- ✘ Explosion windows.

Type	A	BT	C	E	F	H	I	L	M	N	O	P1	Q	R	S	U	W
EC5	857	615	270	530	50	250	147	440	555	106	373	517	160	591	530	245	295
EC6	1083	765	352	677	70	330	187	565 545	683	106	445 415	645 593	160 200	750	680	270	320
EC8	1225	1025	423	748	160 162	472	186	590 660	824	106	550 530	750	160 200	920	820	320	370

Copyright ? - The right to alterations is reserved