

Cimbria HEID GmbH

Heid Werkstrasse 4

2000 Stockerau - Austria

Telefon: (43) 2266-699-0

Telefon: (43) 2266-699101

Telefax: (43) 2266-65590

e-mail : heid@cimbria.at – wbo@cimbria.atInternet: www.cimbria.com or www.cimbriakaack.com**KSE 510**

Compact Huller Unit for Dry Cherry Coffee

Groupe Décortiqueur Compact à Café en Cérises Sèches

Unidad compacta para Cafe Cereza seca

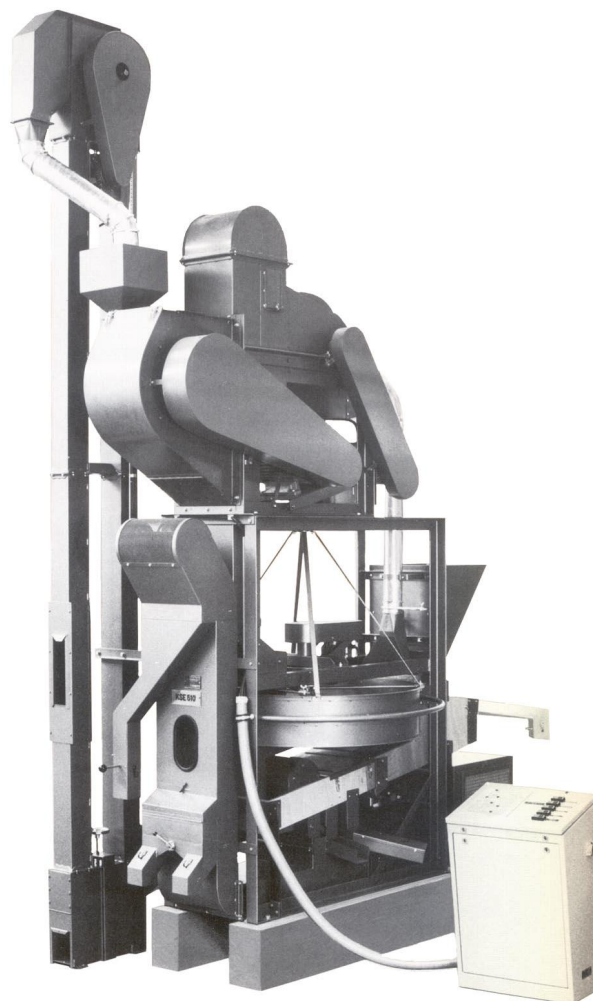

Technical data	Données Techniques	KSE 510
Output	Débit	800 – 1200 kg / h
(Hulled coffee, based on perfectly dried cherry coffee)	(Café décortiqué, sur base de café en cerises parfaitement séché)	
Power requirement	Puissance requise	10 – 12 kW
Weight – gross - net	Poids - brut - net	1.900 kg - 1.499 kg
Shipping space	Cubage	11,5 m³

KSE 510

Compact Huller Unit for Dry Cherry Coffee

The special KAACK MASCHINEN design for small farms and cooperatives, allowing the production of marketable clean hulled coffee out of perfectly dried cherry coffee (Mbuni).

The complete Compact Huller Unit consist of:

- Universal Pre-Cleaner and De-stoner with fan in a dust resistant housing with easily exchangeable filter elements.
- Cup and Belt Elevator feeding the Impact Huller.
- Cross Beater Impact Huller for „cool hulling“.
- Pneumatic Husk Separator.
- Separator and recycling system for un-hulled cherries.
- Catador for pneumatic separation of light impurities with twin outlet for the coffee beans, allowing a continuous bag exchange.
- Dust extraction device for the inlet hopper.
- Central Switch Desk with graphic diagram and unique fully automatic disconnecting system in case of failure in power supply or similar trouble.
- Belt guards for all driving systems.

Further advantages:

- High output with moderate power consumption.
- Individual motor drives with sufficient power reserve for:
 - Pre-Cleaner and Catador
 - Impact Huller
 - Husk Separator
 - Swinging Sieve for the separation of un-hulled coffee cherries
 - Elevator

Providing constant speeds for every component, independent of varying charges of other components, thus maintaining an optimal and smooth performance.

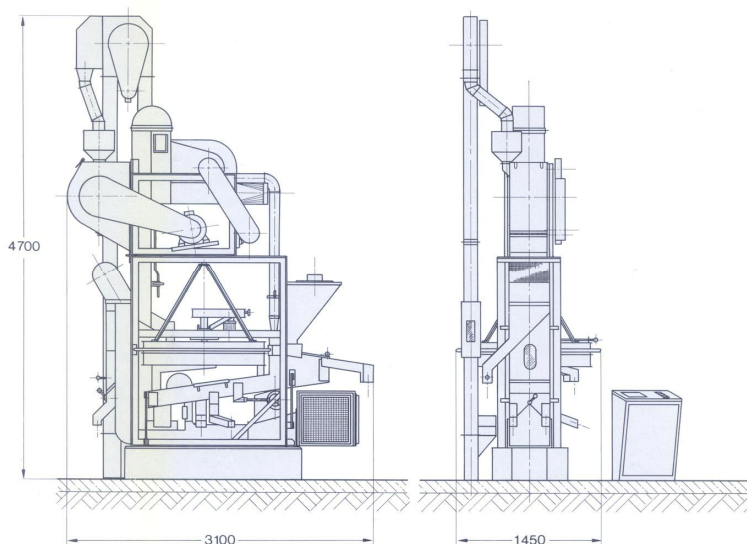

Cimbria HEID GmbH

Heid Werkstrasse 4

2000 Stockerau - Austria

Telefon: (43) 2266-699-0

Telefon: (43) 2266-699101

Telefax: (43) 2266-65590

e-mail : heid@cimbria.at – wbo@cimbria.at

Internet: www.cimbria.com or www.cimbriakaack.com

